

GAMMA 5A

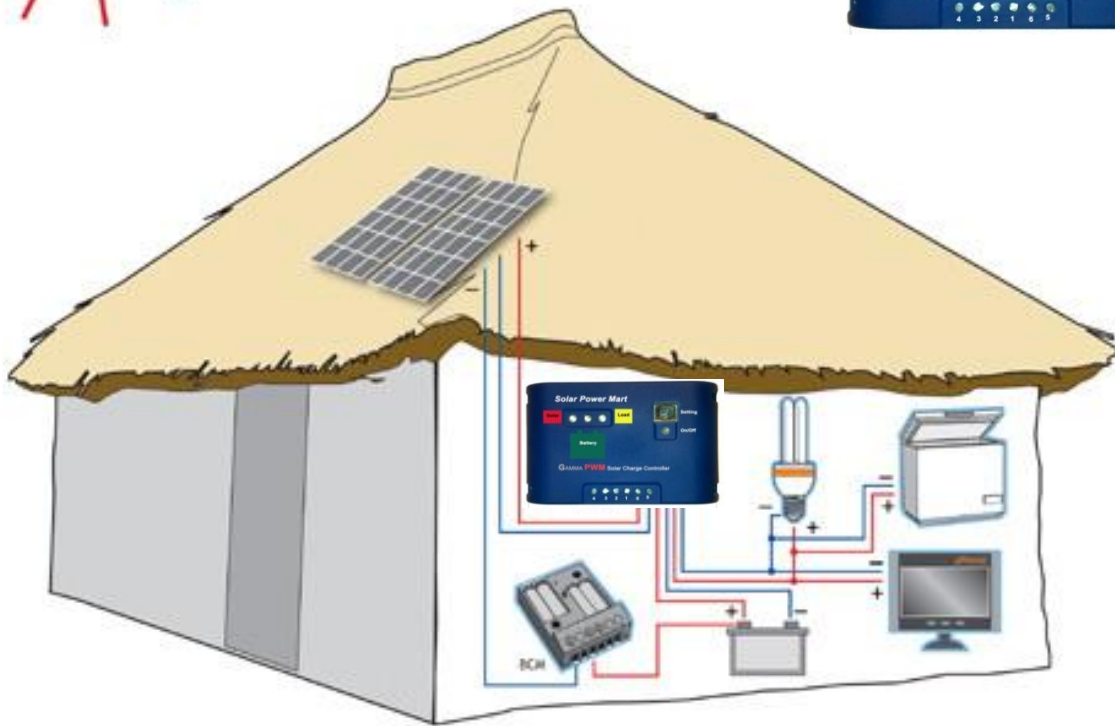

USER MANUAL

GAMMA 5A SOLAR CHARGE CONTROLLER

RATINGS (12V)

GAMMA 5A, 12V, 5Amp

NOTES: For use with solar panels only

TECHNICAL INFORMATION

12Volt

Rated solar input	5A
Rated load	5A
25% Current overload	1 min.
Load disconnect	11.1V
Load re-connect	12.6V
Equalization voltage (10 minutes)	14.6V
Boost voltage (10 minutes)	14.4V
Float voltage	13.6V
Temp Comp. (mV/°C)	-30mV
Temperature	-35°C to +55°C

QUICK START INSTRUCTIONS

Please review the entire manual to ensure best performance and hassle-free services.

1. Mount the controller to a vertical surface.
2. Allow space above and below the controller for air ventilation.
3. Make sure the PV and load currents do not exceed the ratings of the controller being installed.
4. It is recommended that the connections be made in the order of 1 to 6 (see schematic below).

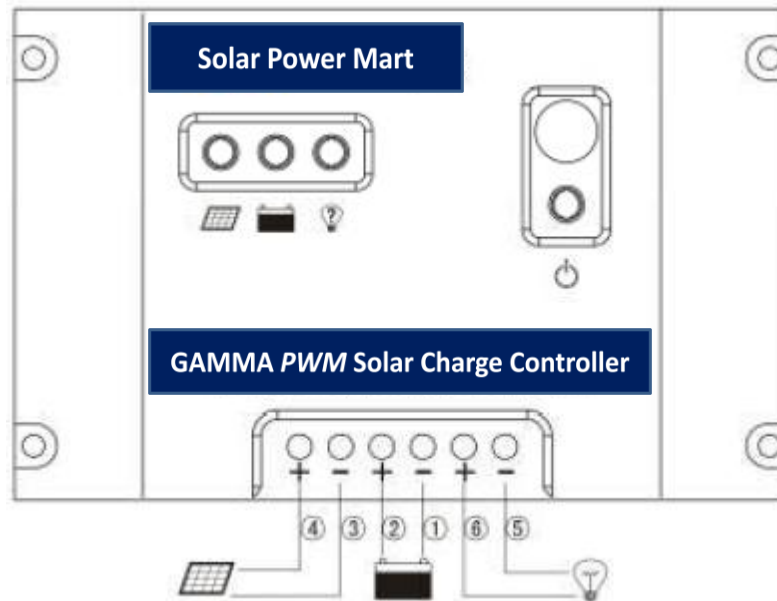

- Use with 12V batteries only
- Use with 12V systems only

5. Connect the **BATTERY** first.

CAUTION: Naked wires do not get in touch with the controller metal case

6. Connect the **SOLAR** (PV array) next. The green LED indicator will light on if sunlight is present.
7. Connect the **LIGHT/ LOAD** at final stage. If the red LED indicator lights on, the battery capacity is low and should be charged before completing the system installation.
8. Press the **BUTTON** as 6. or 7. to verify if system is connected.

LIGHTING CONTROL OPTIONS



9. Press the power switch for 5 seconds, and select the desired LIGHTING CONTROL option. The LED is on, which confirmed you have selected the right one.
10. The controller requires 10 minutes of continuous transition values before it starts to work. These constraints avoid false transitions due to lightning or dark storm clouds.
11. The controller requires 10 minutes relay before it begins operational.
12. Brief description as followings:

Number 0	Dusk-toDawn, light is on all night
Number 1	Light turns on at dusk for 1 hour
Number 2	Light turns on at dusk for 2 hour
Number 3	Light turns on at dusk for 3 hour
Number 4	Light turns on at dusk for 4 hour
Number 5	Light turns on at dusk for 5 hour
Number 6	Light turns on at dusk for 6 hour
Number 7	Light turns on at dusk for 7 hour
Number 0	Light turns on at dusk for 8 hour
Number 1	Light turns on at dusk for 9 hour
Number 2	Light turns on at dusk for 10 hour
Number 3	Light turns on at dusk for 11 hour
Number 4	Light turns on at dusk for 12 hour
Number 5	Light turns on at dusk for 13 hour
Number 6	Light remains off, ON/OFF mode
Number 7	Test mode, light is on after it detects no light, light is off after it detects light

LED INDICATOR

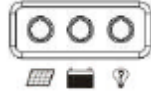

Green ON when solar is charging battery
Green blinks when the system is over voltage



Green ON when battery level is in the right range
Green slowly flashing when battery level is full
Yellow ON when battery level is low
Red ON when loads are cut off



Red ON when the output is on.
Red slowly flashing when its over load
**(the load amp is 1.25 times of rated current for 60 seconds,
or the load amp is 1.5 times of rated current for 5 seconds)**
Red blinks when the load is short-circuit.

Please note:

1. The output will cut off once there is over load or short circuit.
2. Disconnect all the equipments and reconnect.
3. Press the button, controller will resume operational after 10 seconds, or wait for it to operate on the next day.

TROUBLESHOOTING

1. Charging LED indicator is off when it is daytime

- a. The green Charging LED should be on if its day time.
- b. Check that the proper battery type has been selected.
- c. Check that all wire connections in the system are correct and tight. Check the polarity (+ and -) of the connections.
- d. Measure the PV array open-circuit voltage and confirm it is within normal limit. If the voltage is low or zero, check the connections at the PV array itself. Disconnect the PV from the controller when working on the PV array.
- e. Measure the PV voltage and the battery voltage at the controller terminals. If voltage at the terminals is the same (within a few tenths of volts) the PV array is charging the battery. If the PV voltage is close to the open circuit voltage of the panels and the battery voltage is low, the controller is not charging the batteries and may be damaged.

2. Charging LED indicator is blinking

- a. First check the operating conditions to confirm that the voltage is higher than specifications. Consider the temperature compensation of the controller's PWM setpoint. For example, at 0°C the controller will regulate at about **15 volts**
- b. Check that all wire connections in the system are correct and tight.

3. Load LED indicator is blinking, flashing, or turned red (load is not operating properly)

- a. Check that the load is turned on. Check that no system fuses are defective.
- b. Check connections to the load, and other controller and battery connections. Make sure voltage drops in the system wires are not too high.
- c. If the LED indicator is blinking and no output, check if the load is short-circuit. Disconnect the load, and press the switch button, the controller will return to work after 30 seconds.
- d. If the LED indicator is flashing and no output, check if the load is over the rated power. Reduce the load, and press the switch button, the controller will return to work after 30 seconds.

INSPECTION AND MAINTENANCE

The following inspections and maintenance tasks are recommended at least once per year for optimum controller performance.

1. Confirm that the correct battery type has been selected.
2. Confirm that the current levels of the solar array and load do not exceed the controller ratings.
3. Tighten all the terminals. Inspect for loose, broken, or burnt wire connections. Be certain no loose strands of wire are touching other terminals.
4. Press the TEST button (number: 6 or 7) to verify if the lights are working.
5. Check that the controller is securely mounted in a clean environment. Inspect for dirt, insects, and corrosion.
6. Check the air flow around the controller is not blocked.
7. Protect from sun and rain. Confirm that water is not collecting under the cover.
8. Check that the controller functions and LED indicators are correct for the system conditions at that time.
9. Make sure the PV array is clean and clear of debris and snow. Confirm the array is oriented correctly for the installation location.

SYSTEM MAIN CIRCUIT DIAGRAM

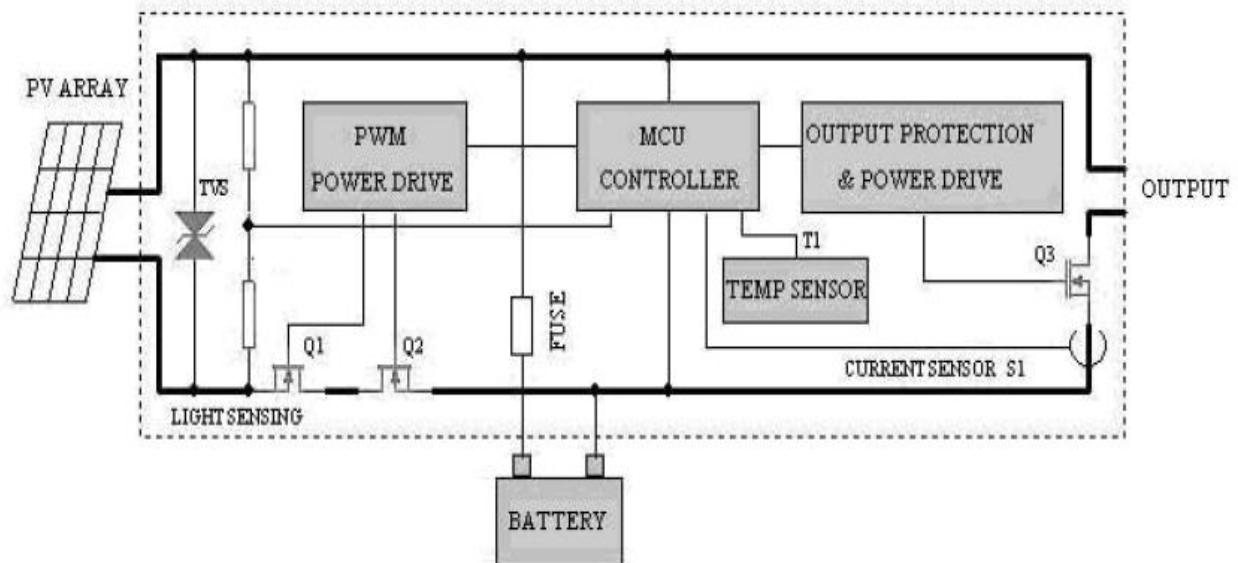

MECHANICAL

